

VISIONTRACK

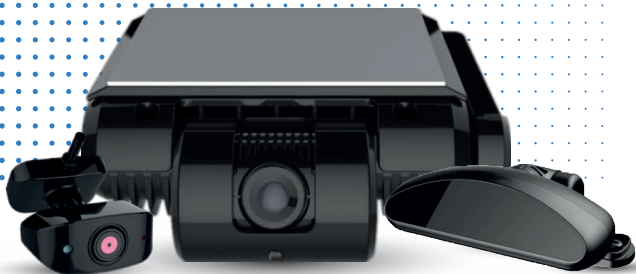

VT3000-AI INSTALLATION GUIDE

THE UK'S MOST AWARD-WINNING CAMERA TELEMATICS COMPANY



www.visiontrack.com

Table of Contents:

- 2. Important Information**
- 3. Overview**
 - 1.1 System Diagram
 - 1.2 Packing List
 - 1.3 Required Tools
 - 1.4 VT3000-AI Details
- 8. System Installation Overview**
 - 2.1 MDVR Install
 - 2.2 Power Supply, Ignition & IO Signal
 - 2.3 Speed Signal & Serial Ports
 - 2.4 Install SIM & SD Cards
- 10. Installation and Calibration**
 - 3.1 VT3000-AI Installation
 - 3.2 VT3000-AI Camera Calibration
 - 3.2 VT3000-AI Camera Calibration
 - 3.4 DSM Camera FOV
 - 3.5 DSM Calibration
 - 3.5 Install the IPC Cab Camera (if applicable)
- 18. Speed Signal**
- 19. Commissioning**

Important Information:

- Before you begin installing and commissioning the system, please ensure that you have read this manual thoroughly referring to any supplementary information provided for the unit as required.
- Care must be taken in the routing of all cables so that the insulation does not become worn or damaged.
- Unauthorised modification to this equipment or associated accessories is unadvised without the expressed permission and agreement from the product manufacturer.
- This equipment should not be operated in hazardous environments i.e. areas that contain explosive materials or flammable vapours.
- This equipment should not be operated within aircrafts or in close proximity to medical equipment.
- This equipment may only be located in a position where it cannot interfere with the normal operation of the vehicle or present a hazard to the driver or passengers.
- Failure to comply with the following Warnings, Approval and Safety information may invalidate warranty, certification or type approval of this product.
- All installation and service work must be carried out in accordance with FCSI362, FCSI372, RQAS, 95/54/EC, ISO 21609 and / or any other statutory guidelines or Directives currently in force. Therefore it is strongly recommended that the unit is installed and commissioned by suitably trained and qualified installation personnel with accreditation.
- Under no circumstances may any part of the product be installed inside the engine compartment area.
- Unauthorised changes or alterations to the equipment or the installation will invalidate certification issued by the Approved Accreditation Bodies and may also affect the vehicle manufacturers warranty.
- To avoid interference the VisionTrack power supply MUST be installed as far away as possible from other telematics devices and power supplies already installed within the vehicle. Ideally, installation should be on the opposite side of the vehicle.

1. Overview

VisionTrack's **VT3000-AI** is a cost-effective mobile video surveillance device specially designed for remote video and driver safety monitoring for every vehicle type.

The solution has three components:

VT3000-AI (ADAS Camera),

VT-DSM-AI camera and the

VT-C26-IPC, which integrates multiple modules, such as 4G, Wi-Fi and G-sensor.

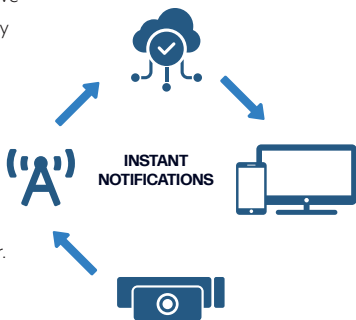

Key features:

Industry-leading, connected and HD-quality vehicle camera and telematics system



Provides First Notification of Loss (FNOL) alerts

Provides HD images before, during and after an incident



Accurate G-shock sensor measures impact force and driving style

Monitor driver behaviour from anywhere using the VisionTrack IoT platform



Supports GPS and GLONASS receiver with self-checking notifications

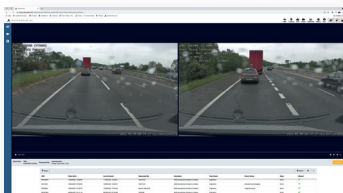

1.1 System Diagrams



VT3000-AI Main Cable

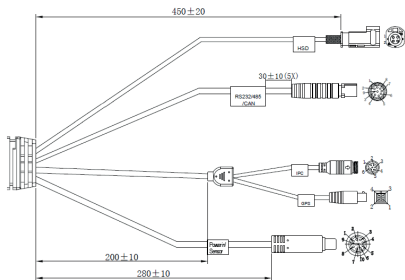

PIN define			
DP15-30P	ESD-B		
1PX	1	0-	White
1PX+	4	0+	Gray
Red 12	2	+12V	Red
Black 17	3	0V	Black
Ring terminal	Shield		External shield
DP15-30P	SP4 Male		
30	1	0V-L	Green
21	2	0V-R	White
30	3	45V+	Brown
29	4	0V-B	Gray
26	5	232V+	Blue
25	6	232V+	Yellow
22	7	+5V	Orange
28	8	+12V	Red
27	9	0V	Black
DP15-30P	RS45-6 Male		
3	4	8V+	Green
4	5	8V+	Yellow
1	1	7V+	Orange
2	2	7V+	White
12	3	+12V	Brown
13	6	0V	Grey
Ring terminal	Shield		
TJ33-08-P1-2S	Mini D55M4P		
123-01-11	1	0V-01	Blue
123-01-11	2	0V-11	Pink
	3	0V-11	Red
	4	0V	Black
TJ33-08-P1-5	10VW Female		
123-01-11	1	0V	Grey
081-01-14	2	5 V 2V1	Green
2630V2C	5V2G	3	0V 2V1
123-01-11	4	5 V 2V1	Purple
123-01-11	5	5 V 2V1	Brown
	6	ACC	Orange
123-01-11	7	5 V 2V2	Yellow
081-01-11	1	0V	Pink
081-01-11	9	0V	White
2630V2C	2-3	10V 2V1	Black 24AWG

1.2 Packing List*:



VT3000-AI



VT-DSM-AI



Additional IPC
Camera



9-Pin Power Cable



GPS Receiver



Serial Cable



Torx T8 Screwdriver



VT-R Watch V2



Wipe



SD Card



Standard SIM Card



VT-EASYCHECK



J1939 Connector



6-PIN IPC Extension
Cable 3m



2A Mini-blade
Fuse

*Contents subject to kit purchased



1.3 Required Tools:



Plastic Trim Tool



Screw Driver



Cable Ties



Drill



Marker Pen

USB Flash Drive
(Optional)

Wire Cutter



Wire Stripper



Self Tapping Screws



Allen Keys



5M/50M Tape Measure



Crimping Tool



Electrical Tape



Multimeter



Amalgamating Tape

1.4 VT3000-AI Features:



2. System Installation Overview

2.1 System Install

Mount the VT3000-AI on the windscreen

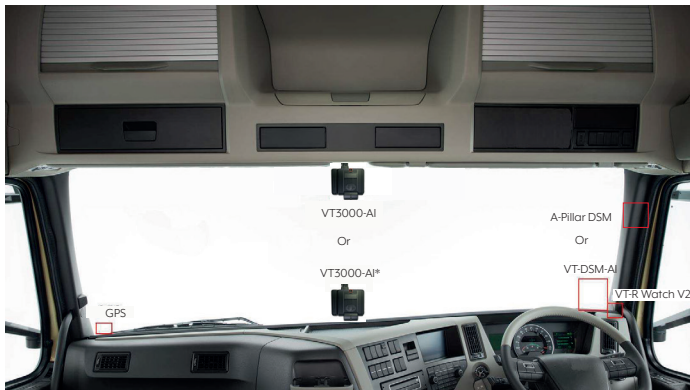

*When mounted lower down the windscreen, all cables need to be mounted at the top of the windscreen.

2.2 Power Supply, Ignition & IO Signal

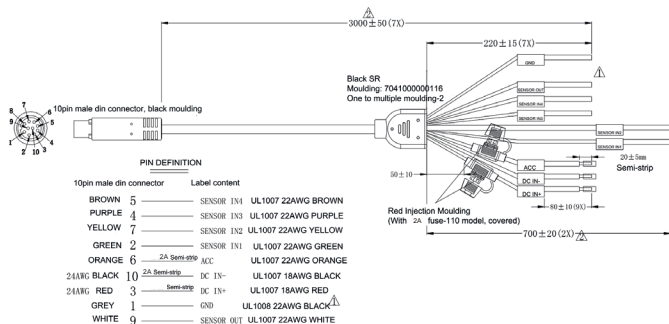

2.3 Speed Signal & Serial Ports

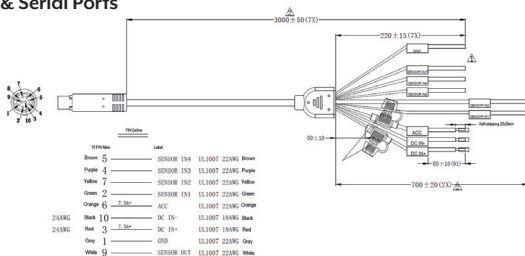

The vehicle speed can be read from the pulse signal from the vehicle, a CAN port or GPS, for detailed settings see section 4.

2.4 Install SIM & SD Cards

Standard size SIM card:



Check the SD card's write protection switch, which should be in the "on" position.



Check "write enable"
of SD Card

3. Install and Calibration

Depending on the model of the vehicle, select the most appropriate installation location (for install and maintenance).

GPS and 4G antenna are pointed towards the sky.

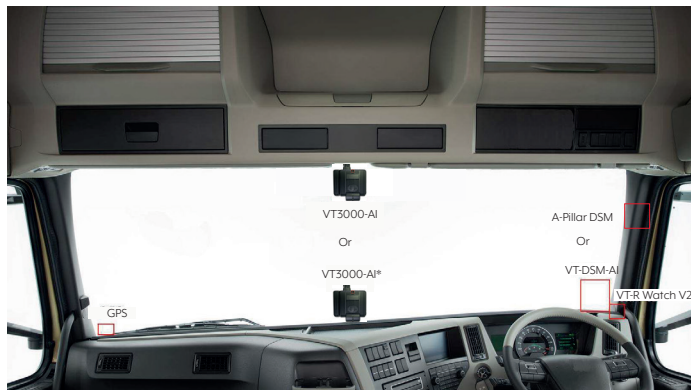

Remove the bracket from the rear to enable install, (slide top to remove).

Remove the cover and install the SD card and SIM card**.



**This may already be done for you.

3.1 VT3000-AI Installation

IMPORTANT: Degrease and clean the windscreen before attaching.

The **VT3000-AI** should be mounted in the middle at the top of the window screen, ensuring the lens is within the swept area of the wipers. All cables should be going towards the roof. Maximum height should be no more than 4m high and always check the live image in easycheck before securing to the window.



The **VT3000-AI** can also be fitted at the bottom of windscreen on HGVs.



3.2 VT3000-AI Camera Calibration*

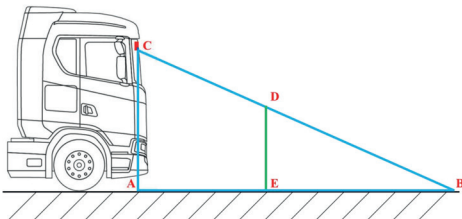

*You may need VT Commission Support for this step. Refer to the Commissioning section on **page 19**.

Basic trigonometry functions:

$$\frac{AC}{AB} = \frac{ED}{EB}$$

Assuming the VT3000-AI camera install height is **AC= 3m**, the ideal calibration reference point **AB= 30m** and we only have **AE=5 m** of level ground in front of the vehicle.

Thus, find the ED: $ED = 2.5m$

Then place a 2.5m high reference point **in front of the lens** that is 5m away.
(Please note the ED might change when the camera is installed higher)

Open the settings of the VT3000-AI, enter the ADAS camera install height (AC) in the "Algorithm" menu (Easycheck APP).

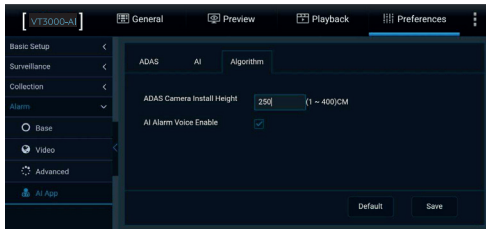

Open the "ADAS" menu, set the Mode Type to "Calibration" then click save*.

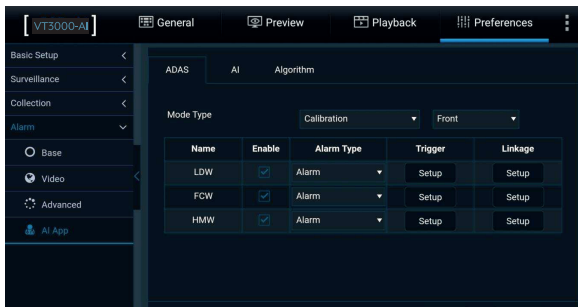

Refer to the live view again, 3 horizontal line should show in the image for reference. Adjust the ADAS camera lens angle (remove the ADAS camera cover on the back) that will allow the 30m reference line up with the reference point **DE** as mentioned above*.



*You may need VT Commission Support for this step. Refer to the Commissioning section on **page 19**.

Finish the ADAS camera calibration by changing it to Normal mode then click ok.

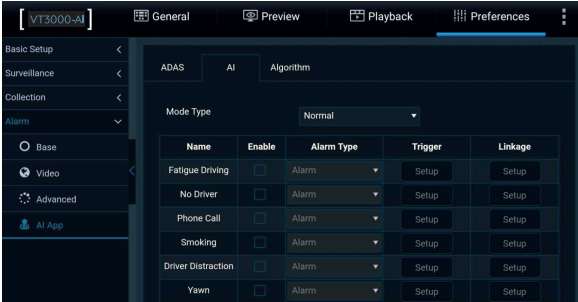

The screenshot shows the 'Preferences' tab in the VisionTrack software. Under the 'ADAS' section, the 'Mode Type' is set to 'Normal'. Below this, there is a table of ADAS features:

Name	Enable	Alarm Type	Trigger	Linkage
Fatigue Driving	<input type="checkbox"/>	Alarm	Setup	Setup
No Driver	<input type="checkbox"/>	Alarm	Setup	Setup
Phone Call	<input type="checkbox"/>	Alarm	Setup	Setup
Smoking	<input type="checkbox"/>	Alarm	Setup	Setup
Driver Distraction	<input type="checkbox"/>	Alarm	Setup	Setup
Yawn	<input type="checkbox"/>	Alarm	Setup	Setup

3.3 DSM Camera Installation

Install the DSM in the location according to the system installation diagram (section 3). The bottom screws must be tightened and camera should mount right above the steering wheel on the dashboard in front of the driver.

Secure the camera **AFTER** finishing the calibration.



The DSM camera should mount 70 – 120cm between the driver's eyes.



3.4 DSM Camera FOV

The driver camera FOV should cover the facial area of the driver and the tops of the shoulders. Allow space to the left, right, up, down for more flexibility so that it is possible to catch the driver's face when looking in different directions.

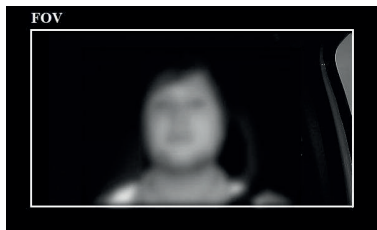

3.5 DSM Calibration*

It is recommended to have the actual driver perform the calibration. If this is not possible, it is best to ask a person with a similar height for help.

Open the IPC settings of the DSM camera channel, e.g. Channel 5.

Keep the device name as "DSM" and select "Calibration", set "Front" or "Side" depending on the installation location.

Name	Enable	Alarm Type	Trigger	Linkage
Fatigue Driving	<input type="checkbox"/>	Alarm	Setup	Setup
No Driver	<input type="checkbox"/>	Alarm	Setup	Setup
Phone Call	<input type="checkbox"/>	Alarm	Setup	Setup
Smoking	<input type="checkbox"/>	Alarm	Setup	Setup
Driver Distraction	<input type="checkbox"/>	Alarm	Setup	Setup
Yawn	<input type="checkbox"/>	Alarm	Setup	Setup

*You may need VT Commission Support for this step. Refer to the Commissioning section on [page 19](#).

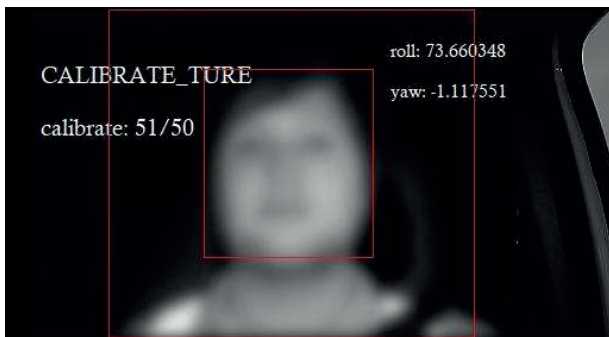

Finish the driver camera calibration by changing it back to “Normal mode” then secure on the dashboard.

3.5 Install the VT-C26-IPC Cab Camera (if applicable)

Install the IPC camera inside the driver's cab, FOV example shows in figure below:



4. Speed Signal

There are **two ways** to acquire the vehicle speed signal that may be used for the VT3000-AI.

Speed Pulse

Speed pulse is more accurate than GPS speed as it has direct access to the vehicle, also it may take time to find the speed pulse signal from the vehicle for wiring and calibration.

Find the "Pulse" in the "Speed" menu.

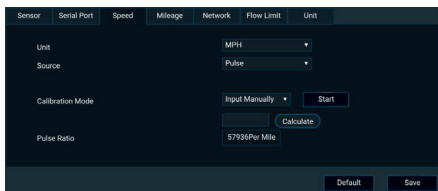

The screenshot shows the VisionTrack configuration interface with the "Speed" tab selected. The "Source" dropdown menu is set to "Pulse". The "Unit" dropdown menu is set to "MPH". The "Calibration Mode" dropdown menu is set to "Input Manually", and there is a "Start" button next to it. The "Pulse Ratio" field is set to "57936Per Mile" and there is a "Calculate" button next to it. At the bottom right, there are "Default" and "Save" buttons.

Satellite

GPS speed may have latency that may affect the accuracy of the alarms, but it is acceptable for most applications. Find the "Satellite" in the "Speed" menu.

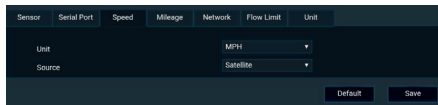

The screenshot shows the VisionTrack configuration interface with the "Speed" tab selected. The "Source" dropdown menu is set to "Satellite". The "Unit" dropdown menu is set to "MPH". At the bottom right, there are "Default" and "Save" buttons.

Commissioning:

When the cameras are positioned and supplied with power, **wait until the green LED is steady and press the panic button**. You can now use the commissioning app to commission the cameras. To find out more about our commissioning app, please download here: engineering.visiontrack.com. You can also contact the **VisionTrack technical support** on **01246 225 858** to commission the cameras. You will have to give them the Kit number on the box as well as the make, model, colour and registration of the vehicle, an ID number and site information.

It is important to **leave the vehicle ignition ON during the commissioning**. The commissioning team will inform you of any potential faults and make you change the angle of the cameras if they are not correctly adjusted.

The VisionTrack technical support team is available between 9am - 5pm Monday through to Friday and 9am - 5pm on a Saturday.

You will be given a Camera Commissioning Number by the Commissioning Team. It is very important that the commissioning number is recorded on your Job sheet/ticket.

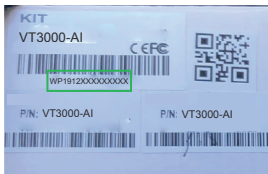



www.visiontrack.com

VT3000-AI INSTALLATION GUIDE



2 Chapman Way
High Brooms Industrial Estate
Tunbridge Wells
Kent
TN2 3EF



VisionTrack Official Website